

# MI-IAM Input Attenuator Modules

MILITARY

## FILTER AND FRONT-END MODULES

### FEATURES

- Inputs: 28 Vdc and 270 Vdc
- MIL-STD-461C/D/E EMI compliance
- MIL-STD-810 environments
- MIL-STD-704A-F, MIL-STD 1275A/B/D & DO-160E transients and spikes
- Reverse polarity protection
- Output power: Up to 200 W from any combination of MI-200 or MI-J00 modules
- Expansion port for additional power
- Short circuit protected
- Size: 2.28" x 2.4" x 0.5" (57,9 x 61,0 x 12,7 mm)



### PRODUCT INFORMATION

The MI-IAM is an accessory product to Vicor's MI-Family of DC-DC converters that provides the EMI filtering and transient protection. Designed for use with all 28 V and 270 V input MI-200 or MI-J00 converters, the MI-IAM can drive any number of modules with output loads to 200 W.

The MI-IAM meets the conducted emissions specifications of MIL-STD-461C/D/E and offers complete input transient, surge, and spike protection to the most severe levels of MIL-STD-1275, MIL-STD-704 and DO-160E. Reverse polarity protection and overvoltage lockout provide additional safeguards against potentially damaging line conditions. High power arrays can be configured using the expansion port capability of the MI-IAM.

### PRODUCT GRADE SPECIFICATIONS

| PARAMETER                            | INPUT                                | MIN                | TYP | MAX  | UNIT      | NOTE                                    |                |
|--------------------------------------|--------------------------------------|--------------------|-----|------|-----------|---|----------------|
| 28 Vdc modules                       | Steady state input                   | 16                 | 28  | 50   | Vdc       |   |                |
|                                      | Input spike limit                    | -600               |     | 600  | Vdc       | 10 $\mu$ s, per MIL-STD-704A            |                |
|                                      |                                      | -250               |     | 250  | Vdc       | 70 $\mu$ s, 15 mJ per MIL-STD-1275A/B/D |                |
|                                      | Input surge limit                    |                    |     | 100  | Vdc       | 50 ms, 0.5 per MIL-STD-1275A/B/D        |                |
|                                      |                                      |                    |     | 80   | Vdc       | 100 ms per DO-160E                      |                |
|                                      | Overvoltage shut down <sup>[a]</sup> | 50                 |     |      | Vdc       | 100 ms, automatic recovery              |                |
|                                      | Reverse polarity protection          |                    |     |      |           | Shunt diode: input fuse required        |                |
|                                      | Recommended fuse                     |                    |     | 20   | Amps      | F03A type                               |                |
|                                      | 270 Vdc modules                      | Steady state input | 125 | 270  | 400       | Vdc                                     |                |
|                                      |                                      | Input spike limit  |     |      | 800       | Vdc                                     | 10 $\mu$ s, 50 |
| -600                                 |                                      |                    |     | 600  | Vdc       | 100 $\mu$ s, 15 mJ                      |                |
| Input surge limit                    |                                      |                    |     | 500  | Vdc       | 100 ms, 0.5                             |                |
| Overvoltage shut down <sup>[a]</sup> |                                      | 400                |     |      | Vdc       | 100 ms, automatic recovery              |                |
| Reverse polarity protection          |                                      |                    |     |      |           | Shunt diode: input fuse required        |                |
| Recommended fuse                     |                                      |                    | 4.0 | Amps | F03A type |   |                |

<sup>[a]</sup> The MI-IAM disables downstream converters and clamps the converter input voltage at a safe level

### GENERAL SPECIFICATIONS

(At TBP = 25°C, nominal line and 75% load, unless otherwise specified)

| PARAMETER  | MIN                       | TYP | MAX | UNIT | NOTE  |
|------------|---------------------------|-----|-----|------|-------|
| All models | No load power dissipation |     | 0.5 | 1.5  | Watts |
|            | Inrush current            |     | 110 | 125  | % IIN |

### EMI CHARACTERISTICS MIL-STD-461

|                   |                          |                         |                |
|-------------------|--------------------------|-------------------------|----------------|
| Input power leads | Conducted emissions      | CE01, CE03, CE07        | MIL-STD-461C   |
|                   |                          | CE101, CE102            | MIL-STD-461D/E |
|                   | Conducted susceptibility | CS01, CS02, CS06, CS101 | MIL-STD-461C   |
|                   |                          | CS114, CS115, CS116     | MIL-STD-461D/E |

### OUTPUT CHARACTERISTICS

|                       |               |               |                     |      |                                    |
|-----------------------|---------------|---------------|---------------------|------|------------------------------------|
| Clamp voltage         | 28 Vdc input  | 60            | Vdc                 |      |                                    |
|                       | 270 Vdc input | 420           | Vdc                 |      |                                    |
| Output power          |               | 250           | Watts               |      |                                    |
| Internal voltage drop | 28 Vdc input  | 0.6           | Vdc                 |      |                                    |
|                       | 270 Vdc input | 0.85          | Vdc                 |      |                                    |
| Overload protection   |               |               | Foldback threshold; |      |                                    |
|                       |               | 28 Vdc input  | 20                  | Amps | auto recovery                      |
|                       |               | 270 Vdc input | 4                   | Amps | with latched shut down after 10 ms |

### ISOLATION CHARACTERISTICS

|                |       |      |
|----------------|-------|------|
| Input to base  | 1,500 | Vrms |
| Output to base | 1,500 | Vrms |

### ENVIRONMENTAL – MIL-STD-810

|                             |          |         |                         |
|-----------------------------|----------|---------|-------------------------|
| Altitude - Method 500.2     | 70,000   | feet    | Procedure II            |
| Humidity - Method 507.2     | 88 / 240 | % / hrs | Procedure I, cycle 1    |
| Acceleration - Method 513.3 | 9        | g       | Procedure II            |
| Vibration - Method 514.3    | 20       | g       | Procedure I, category 6 |
| Shock - Method 516.3        | 40       | g       | Procedure I             |

### RELIABILITY – MIL-HDBK-217F (MI-A22-MU)

|                                       |       |           |
|---------------------------------------|-------|-----------|
| 25°C Ground Benign: G.B.              | 5,637 | 1,000 hrs |
| 50°C Naval Sheltered: N.S.            | 1,014 | 1,000 hrs |
| 65°C Airborne Inhabited Cargo: A.I.C. | 795   | 1,000 hrs |

### THERMAL CHARACTERISTICS

|                                  |      |         |                                  |
|----------------------------------|------|---------|----------------------------------|
| Efficiency                       | 97   |         |                                  |
| Baseplate to sink                | 0.14 | °C/Watt |                                  |
| Operating temperature, baseplate | +100 | °C      | See product grade specifications |
| Storage temperature              | +125 | °C      | See product grade specifications |

### MECHANICAL SPECIFICATIONS

|        |          |                |
|--------|----------|----------------|
| Weight | 3.0 (85) | ounces (grams) |
|--------|----------|----------------|

# MI-IAM Input Attenuator Modules

FILTER AND FRONT-END MODULES

MILITARY

## SAFE OPERATING AREA [B]

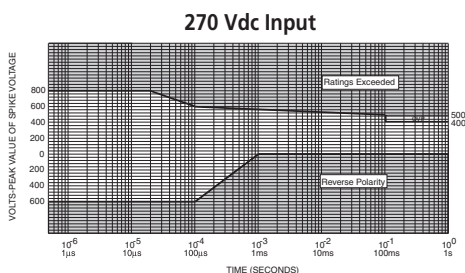
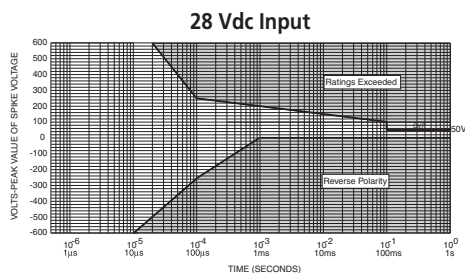

[b] Refer to input characteristics on previous page.

## MODEL SELECTION

| MODEL NUMBER | NOMINAL INPUT VOLTAGE | INPUT RANGE   | COMPATIBLE MI-FAMILY    | CONVERTER |
|--------------|-----------------------|---------------|-------------------------|-----------|
| MI-A22-MU    | 28 Vdc                | 16 – 50 Vdc   | MI-22x-Mx and MI-J2x-Mx | M-Grade   |
| MI-A66-MU    | 270 Vdc               | 125 – 400 Vdc | MI-26x-Mx and MI-J6x-Mx | M-Grade   |
| MI-A22-IU    | 28 Vdc                | 16 – 50 Vdc   | MI-22x-lx and MI-J2x-lx | I-Grade   |
| MI-A66-IU    | 270 Vdc               | 125 – 400 Vdc | MI-26x-lx and MI-J6x-lx | I-Grade   |

## PRODUCT GRADE SPECIFICATIONS

| PARAMETER   | PRODUCT GRADE     |                    |
|---|-------------------|--------------------|
|   | I-GRADE           | M-GRADE            |
| Storage temperature                                     | -55°C to +125°C   | -65°C to +125°C    |
| Operating temperature (baseplate)                       | -40°C to +100°C   | -55°C to +100°C    |
| Power cycling burn-in                                   | 12 hrs, 29 cycles | 96 hrs, 213 cycles |
| Temperature cycled with power off                       | 12 cycles         | 12 cycles          |
| 17°C per minute rate of change                          | -65°C to +100°C   | -65°C to +100°C    |
| Test data supplied at these temperatures <sup>[c]</sup> | -40°C, +80°C      | -55°C, +80°C       |
| Warranty  | 2 years           | 2 years            |
| Environmental compliance                                | MIL-STD-810       | MIL-STD-810        |
| Derating  | NAVMAT P-4855-1A  | NAVMAT P-4855-1A   |

[c] Test data available for review or download from vicorpower.com

## MECHANICAL

$\frac{in}{(mm)}$

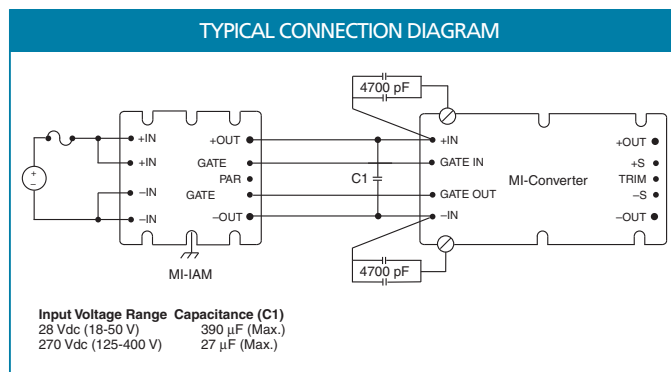
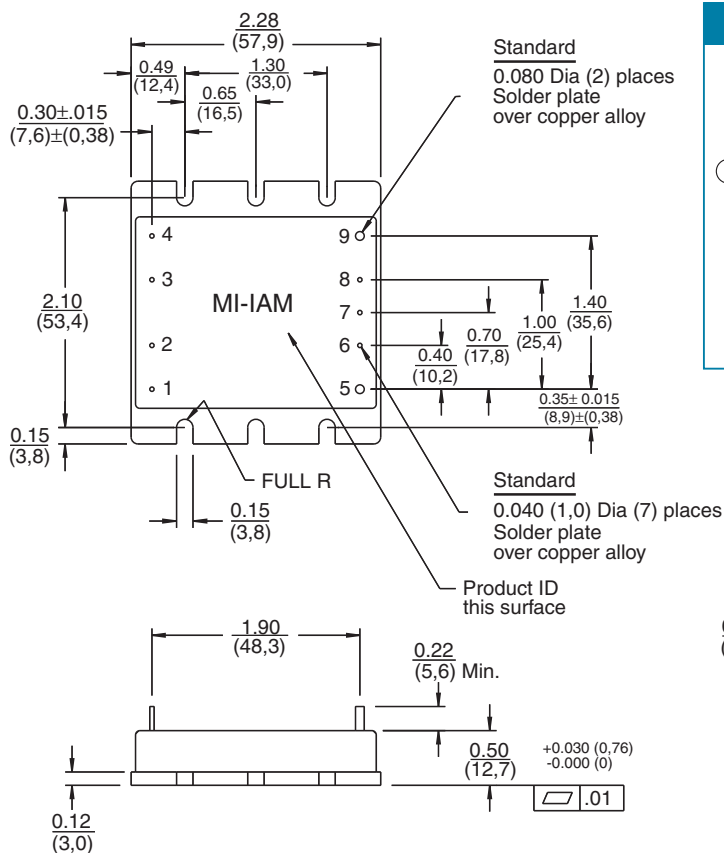

| Pin # | Function |
|-------|----------|
| 1     | +In      |
| 2     | +In      |
| 3     | -In      |
| 4     | -In      |
| 5     | +Out     |
| 6     | Gate In  |
| 7     | Parallel |
| 8     | Gate Out |
| 9     | -Out     |

