

# PBB4A-C Series

1.5-10 WATTS - DC/DC SINGLE & MULTIPLE OUTPUT

## FEATURES

- High power density
- Low profile
- PCB mounting
- 2:1 input ratio
- Regulated output
- Overcurrent protection
- On/off remote control

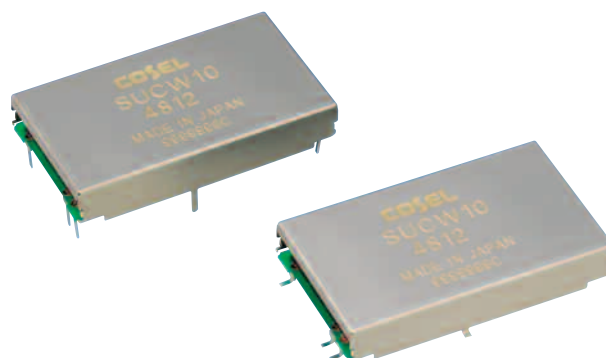

## SPECIFICATIONS

### INPUT

Nominal voltage	5Vdc, 12Vdc, 24Vdc, 48Vdc
Voltage range	4.5-9V, 9-18V, 18-36V, 36-76V
Isolation (input - output)	500Vac 1 minute, cutoff current = 10mA, 500Vdc 50MΩ min (20±15°C).

### OUTPUT

Output voltage	See table
Voltage adjustment	Fixed (TRM pin open) ±5% adjustable by external VR.
Output current	See table
Output voltage setting	Within ±3% of nominal
Ripple & noise	All output 120-150mV pk-pk max (-20 - +55°C) All output 200mV pk-pk max (-40 - -20°C)
Line regulation	Single Out: 5V rail - 20mV, 12V rail - 48mV, 15V rail - 60mV. Dual Out: ±12V rail - 60mV, ±15V rail - 75mV
Load regulation	Single Out: 5V rail - 40mV, 12V rail - 100mV, 15V rail - 120mV. Dual Out: ±12V rail - 60mV, ±15V rail - 750mV
Drift	0.4%
Start-up time	20ms (Minimum input, I <sub>o</sub> = 100%)
Overcurrent protection	Set at approx. 105% of rating and recovers automatically

### OPERATING

Efficiency	72-86% typically
Remote on/off	Provided on all model, except 1.5W module (Negative logic L : ON : OFF).

### STANDARDS AND APPROVALS

Safety	UL60950-1, C-UL, EN60950-1
C-Tick	AS/NZS CISPR11 Group 1 Class A

### ENVIRONMENTAL

Operating temperature	-40°C to 85°C (Required derating).
Operating humidity	20%-95% RH, non condensing
Operating altitude	3000m (10,000feet) max.
Vibration	10Hz-55Hz 10G 3 min period for 60 minutes each along x, y, and z axis
Shock/Impact	50G 11mS once each along x, y and z axis

### MECHANICAL

Dimensions	PBB4A-C-A: 22.4x7.0x13.2mm PBB4A-C-B: 25x7.0x16.1mm PBB4A-C-C: 32.6x7.0x19.1mm PBB4A-C-D: 40.2x7.0x22mm
Weight	PBB4A-C-A: 3g max. PBB4A-C-B: 5g max. PBB4A-C-C: 7g max. PBB4A-C-D: 10g max.

# PBB4A-C Series

1.5-10 WATTS - DC/DC SINGLE & MULTIPLE OUTPUT

DC-DC PCB MOUNTED CONVERTERS & POWER MODULES

## SELECTION TABLE-SINGLE OUTPUTS

MODEL NUMBER	INPUT VOLTAGE VDC	OUTPUT VOLTAGE VDC	OUTPUT CURRENT A	OUTPUT POWER WATT
PBB4A-C053R3A	4.5-9	3.3	0.4	1.5W
PBB4A-C0505A	4.5-9	5	0.3	1.5W
PBB4A-C0512A	4.5-9	12	0.13	1.5W
PBB4A-C0515A	4.5-9	15	0.1	1.5W
PBB4A-C123R3A	9-18	3.3	0.4	1.5W
PBB4A-C1205A	9-18	5	0.3	1.5W
PBB4A-C1212A	9-18	12	0.13	1.5W
PBB4A-C1215A	9-18	15	0.1	1.5W
PBB4A-C243R3A	18-36	3.3	0.4	1.5W
PBB4A-C2405A	18-36	5	0.3	1.5W
PBB4A-C2412A	18-36	12	0.13	1.5W
PBB4A-C2415A	18-36	15	0.1	1.5W
PBB4A-C483R3A	36-76	3.3	0.4	1.5W
PBB4A-C4805A	36-76	5	0.3	1.5W
PBB4A-C4812A	36-76	12	0.13	1.5W
PBB4A-C4815A	36-76	15	0.1	1.5W
PBB4A-C053R3B	4.5-9	3.3	0.6	3W
PBB4A-C0505B	4.5-9	5	0.6	3W
PBB4A-C0512B	4.5-9	12	0.25	3W
PBB4A-C0515B	4.5-9	15	0.2	3W
PBB4A-C123R3B	9-18	3.3	0.6	3W
PBB4A-C1205B	9-18	5	0.6	3W
PBB4A-C1212B	9-18	12	0.25	3W
PBB4A-C1215B	9-18	15	0.2	3W
PBB4A-C243R3B	18-36	3.3	0.6	3W
PBB4A-C2405B	18-36	5	0.6	3W
PBB4A-C2412B	18-36	12	0.25	3W
PBB4A-C2415B	18-36	15	0.2	3W
PBB4A-C483R3B	36-76	3.3	0.6	3W
PBB4A-C4805B	36-76	5	0.6	3W
PBB4A-C4812B	36-76	12	0.25	3W
PBB4A-C4815B	36-76	15	0.2	3W
PBB4A-C053R3C	4.5-9	3.3	1.2	6W
PBB4A-C0505C	4.5-9	5	1	6W
PBB4A-C0512C	4.5-9	12	0.5	6W
PBB4A-C0515C	4.5-9	15	0.4	6W
PBB4A-C123R3C	9-18	3.3	1.35	6W
PBB4A-C1205C	9-18	5	1.2	6W
PBB4A-C1212C	9-18	12	0.5	6W
PBB4A-C1215C	9-18	15	0.4	6W
PBB4A-C243R3C	18-36	3.3	1.35	6W
PBB4A-C2405C	18-36	5	1.2	6W
PBB4A-C2412C	18-36	12	0.5	6W
PBB4A-C2415C	18-36	15	0.4	6W

MODEL NUMBER	INPUT VOLTAGE VDC	OUTPUT VOLTAGE VDC	OUTPUT CURRENT A	OUTPUT POWER WATT
PBB4A-C483R3C	36-76	3.3	1.35	6W
PBB4A-C4805C	36-76	5	1.2	6W
PBB4A-C4812C	36-76	12	0.5	6W
PBB4A-C4815C	36-76	15	0.4	6W
PBB4A-C053R3D	4.5-9	3.3	2.6	10W
PBB4A-C0505D	4.5-9	5	2	10W
PBB4A-C0512D	4.5-9	12	0.9	10W
PBB4A-C0515D	4.5-9	15	0.7	10W
PBB4A-C123R3D	9-18	3.3	2.6	10W
PBB4A-C1205D	9-18	5	2	10W
PBB4A-C1212D	9-18	12	1	10W
PBB4A-C1215D	9-18	15	0.8	10W
PBB4A-C243R3D	18-36	3.3	2.6	10W
PBB4A-C2405D	18-36	5	2	10W
PBB4A-C2412D	18-36	12	1	10W
PBB4A-C2415D	18-36	15	0.8	10W
PBB4A-C483R3D	36-76	3.3	2.6	10W
PBB4A-C4805D	36-76	5	2	10W
PBB4A-C4812D	36-76	12	1	10W
PBB4A-C4815D	36-76	15	0.8	10W

## SELECTION TABLE - MULTIPLE OUTPUT

MODEL NUMBER	INPUT VOLTAGE VDC	OUTPUT VOLTAGE VDC	OUTPUT CURRENT A	OUTPUT POWER WATT
PBB4A-C05D12A	4.5-9	±12 or +24	0.065	1.5W
PBB4A-C05D15A	4.5-9	±15 or +30	0.05	1.5W
PBB4A-C12D12A	9-18	±12 or +24	0.065	1.5W
PBB4A-C12D15A	9-18	±15 or +30	0.05	1.5W
PBB4A-C24D12A	18-36	±12 or +24	0.065	1.5W
PBB4A-C24D15A	18-36	±15 or +30	0.05	1.5W
PBB4A-C48D12A	36-76	±12 or +24	0.065	1.5W
PBB4A-C48D15A	36-76	±15 or +30	0.05	1.5W
PBB4A-C05D12B	4.5-9	±12 or +24	0.13	3W
PBB4A-C05D15B	4.5-9	±15 or +30	0.1	3W
PBB4A-C12D12B	9-18	±12 or +24	0.13	3W
PBB4A-C12D15B	9-18	±15 or +30	0.1	3W
PBB4A-C24D12B	18-36	±12 or +24	0.13	3W
PBB4A-C24D15B	18-36	±15 or +30	0.1	3W
PBB4A-C48D12B	36-76	±12 or +24	0.13	3W
PBB4A-C48D15B	36-76	±15 or +30	0.1	3W
PBB4A-C05D12C	4.5-9	±12 or +24	0.25	6W
PBB4A-C05D15C	4.5-9	±15 or +30	0.2	6W
PBB4A-C12D12C	9-18	±12 or +24	0.25	6W
PBB4A-C12D15C	9-18	±15 or +30	0.2	6W

# PBB4A-C Series

1.5-10 WATTS - DC/DC SINGLE & MULTIPLE OUTPUT

MODEL NUMBER	INPUT VOLTAGE VDC	OUTPUT VOLTAGE VDC	OUTPUT CURRENT A	OUTPUT POWER WATT
PBB4A-C24D12C	18-36	±12 or +24	0.25	6W
PBB4A-C24D15C	18-36	±15 or +30	0.2	6W
PBB4A-C48D12C	36-76	±12 or +24	0.25	6W
PBB4A-C48D15C	36-76	±15 or +30	0.2	6W
PBB4A-C05D12D	4.5-9	±12 or +24	0.45	10W
PBB4A-C05D15D	4.5-9	±15 or +30	0.35	10W
PBB4A-C12D12D	9-18	±12 or +24	0.45	10W
PBB4A-C12D15D	9-18	±15 or +30	0.35	10W
PBB4A-C24D12D	18-36	±12 or +24	0.45	10W
PBB4A-C24D15D	18-36	±15 or +30	0.35	10W
PBB4A-C48D12D	36-76	±12 or +24	0.45	10W
PBB4A-C48D15D	36-76	±15 or +30	0.35	10W

## TECHNICAL ILLUSTRATIONS

### PBB4A-C-A

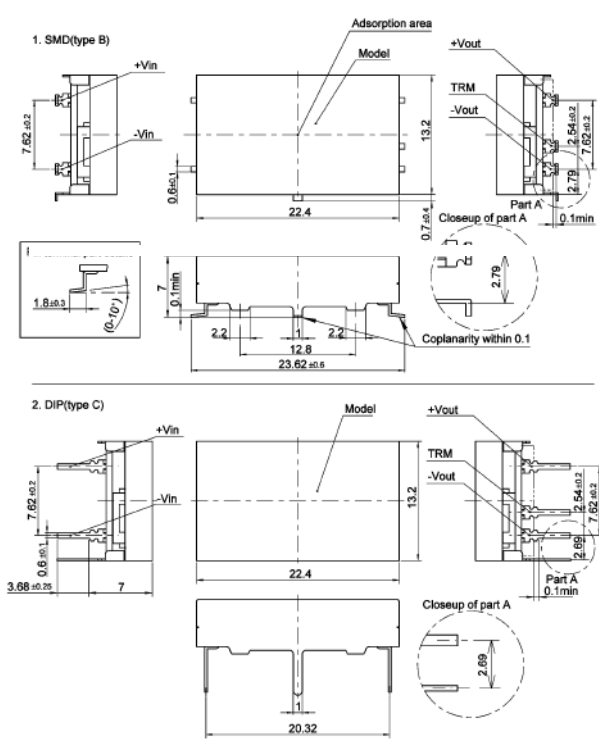

### PBB4A-C-B

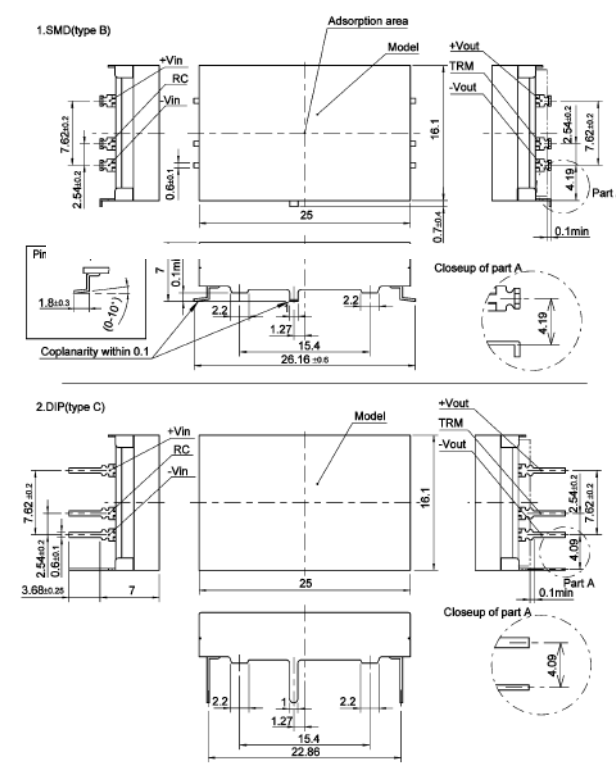

# PBB4A-C Series

1.5-10 WATTS - DC/DC SINGLE & MULTIPLE OUTPUT

DC-DC PCB MOUNTED CONVERTERS & POWER MODULES

## TECHNICAL ILLUSTRATIONS CTND

### PBB4A-C-C

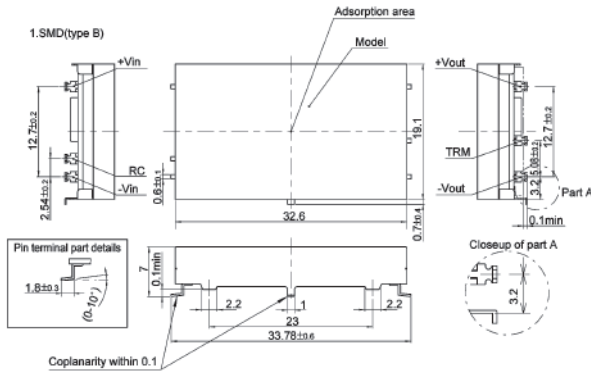

### PBB4A-C-D

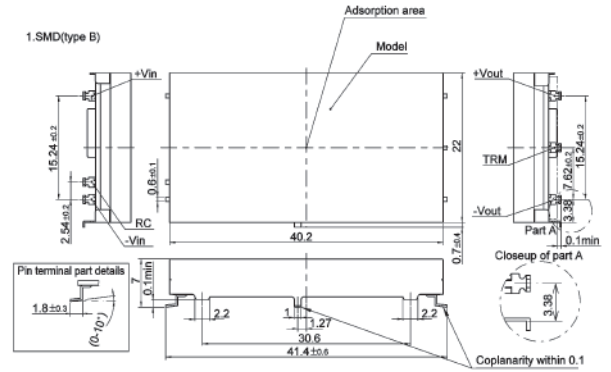

### PBB4A-C-D-A

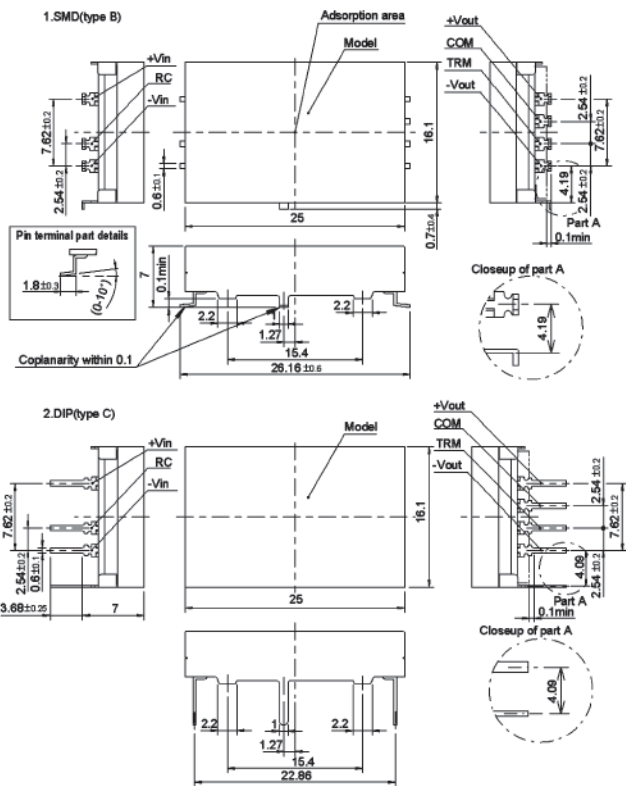

### PBB4A-C-D-B

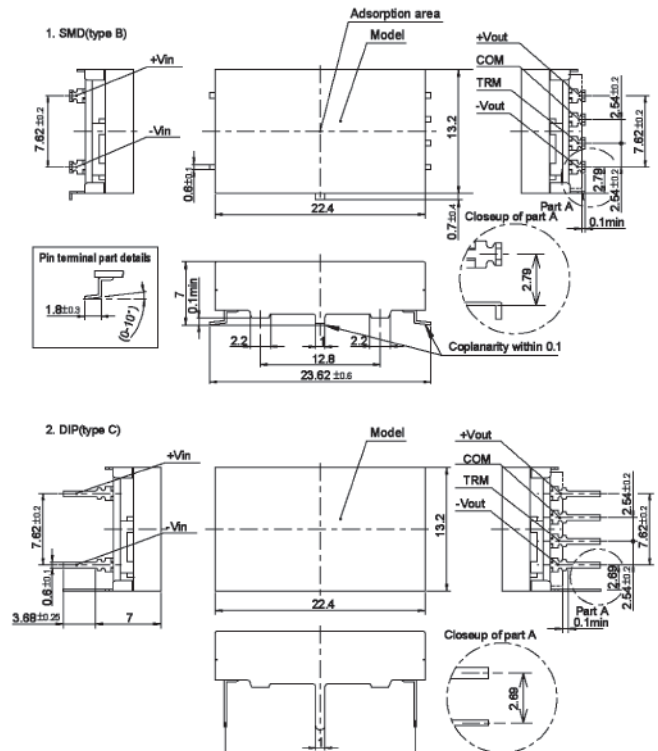

# PBB4A-C Series

1.5-10 WATTS - DC/DC SINGLE & MULTIPLE OUTPUT

## PBB4A-C-D-C

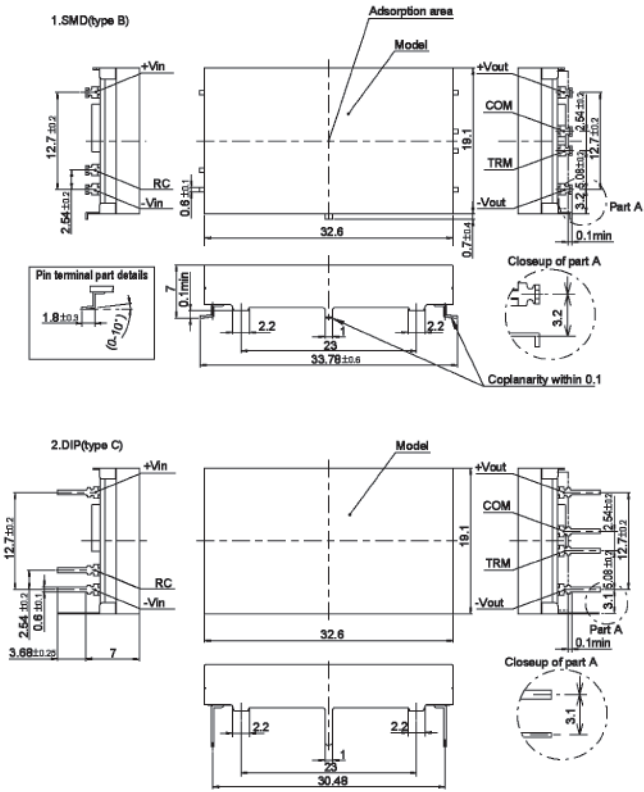

## PBB4A-C-D-D

