

PM450 Series

450-480 WATTS SINGLE & MULTIPLE OUTPUT AC/DC MEDICAL

Features

- **EN61000-3-2 class A and D compliant.**
- **Power factor 0.98 typical.**
- **Remote sense on output 1 and output 2.**
- **Overvoltage protection.**
- **Overcurrent protection.**
- **Power fail detection (PFD) signal.**
- **100% burn-in at full rated load.**
- **Remote inhibit - TTL high disables output.**
- **Short circuit protection.**



Specifications

INPUT

Input Voltage	90-264Vac
Frequency	47Hz-67Hz
Input Current	7.1A (rms) for 115Vac. 3.5A (rms) for 230Vac.
Leakage current	100µA max. @ 115Vac. 60Hz. 165µA max. @ 230Vac. 50Hz.
Isolation	Input – Output: 4000VAC Input – Ground: 1500VAC Output – Ground: 500VAC
Inrush Current	40A @ 115V, 80A @ 230V

OUTPUT

Output Voltage	See table
Output Current	See table
Ripple & Noise	2% peak to peak
Line Regulation	±0.2% maximum at full load.
Load Regulation	See table
Transient Response	Max. deviation 4% recovering to 1% within 500µs after 25% load charge
Overvoltage Protection	Provided on V1 only. Set at 115%-140% of nominal.
Overcurrent Protection	All outputs protected for short circuit conditions
Temperature Coefficient	All outputs ±0.04% per °C.
Holdup Time	Typically 12ms at 110VAC.
PFD Signal	Power fail detection signal. TTL logic low upon loss of input power.
Remote inhibit	Requires an external TTL high level signal to inhibit outputs for standard models.

OPERATING

MTBF	3530,000 hrs @ 25°C
Efficiency	70% minimum.

ENVIRONMENTAL

Operating Temperature	0°C to 70°C
Derating	Derate to 50% at 70°C
Storage Temperature	-40°C to 85°C
Relative Humidity	5%-95% non-condensing

STANDARDS AND APPROVALS

Safety standards	UL2601-1, CSA C22.2, TUV EN60601-1
C-Tick	AS/NZS CISPR11 Group 1, Class A
EMC standards	EN60601-1-2: 2001, EN61000-3-2, -3, EN61000-4-2, -3, -4, -5, -6, -8, -11
EMI standards	EN55011 Class B

MECHANICAL

Dimensions	254x127x63.5mm
Weight	TBA.

PM450 Series

450-480 WATTS SINGLE & MULTIPLE OUTPUT AC/DC MEDICAL

Selection Table

MODEL NUMBER	OUTPUT #1				OUTPUT #2				OUTPUT #3				MAX. OUTPUT POWER
	VNOM	IMIN	IMAX	TOL	VNOM	IMIN	IMAX	TOL	VNOM	IMIN	IMAX	TOL	POWER
PM450-12	12V	0A	37.5A	2%									450W
PM450-13	15V	0A	30A	2%									450W
PM450-14	24V	0A	18.75A	2%									450W
PM450-15	27V	0A	16.7A	2%									450W
PM450-16	30V	0A	15A	2%									450W
PM450-18	48V	0A	10A	2%									480W
PM450-20	24V	1.0A	12A	3%	12V	1.0A	17A	5%					450W
PM450-21	24V	1.0A	12A	2%	15V	0.75A	15A	5%					450W
PM450-22	48V	0.5A	6A	2%	24V	0.5A	10A	5%					450W
PM450-23	48V	0.5A	6A	2%	12V	1.0A	17A	5%					450W
PM450-24	48V	0.5A	6A	2%	15V	0.75A	15A	5%					450W
PM450-30	24V	1.0A	12A	2%	12V	1.0A	17A	5%	3.3V	0A	8A	3%	450W
PM450-31	24V	1.0A	12A	3%	15V	0.75A	15A	5%	3.3V	0A	8A	3%	450W
PM450-32	24V	1.0A	12A	2%	12V	1.0A	17A	5%	5.1V	0A	8A	3%	450W
PM450-33	24V	1.0A	12A	2%	15V	0.75A	15A	5%	5.1V	0A	8A	3%	450W
PM450-34	48V	0.5A	6A	2%	12V	1.0A	17A	5%	3.3V	0A	8A	3%	450W
PM450-35	48V	0.5A	6A	2%	15V	0.75A	15A	5%	3.3V	0A	8A	3%	450W
PM450-36	48V	0.5A	6A	2%	12V	1.0A	17A	5%	5.1V	0A	8A	3%	450W
PM450-37	48V	0.5A	6A	2%	15V	0.75A	15A	5%	5.1V	0A	8A	3%	450W

- NOTES: (1) Add suffix "B" for U-bracket format and "C" for enclosed format.
 (2) All outputs are floating. It can be connected externally for positive or negative output.
 (3) Output 1 and 2 can be adjusted within $\pm 5\%$ of their nominal voltage.
 (4) Output 3 can be adjusted within $\pm 15\%$ of their nominal voltage.
 (5) 450 watts for "C" version with a cover and fan assembly 225 watts for "B" version without moving air (maximum current of output #1 & #2 derated to 70%), or 450 watts with 50 CFM forced air provided by user.
 (6) Single output models may be operated at no-load. At no-load, output voltage tolerance increases to 10%.

Pin Chart

MODEL/PIN	P1(AC)			P2	P3	P4											
	1	2	3			1	2	3	4	5	6	7	8	9	10		
PM450-12 PM450-14 PM450-17	PM450-13 PM450-16 PM450-18	Live	Neutral	Ground	+V	-V	Signal (-V01)	Ground	+S(V01)	-S(V01)	PFD	Inhibit +ve	Inhibit -ve	N.C.	N.C.	0V (Fan)	Fan
PM450-20 PM450-22 PM450-24 PM450-31 PM450-33 PM450-35 PM450-37	PM450-21 PM450-23 PM450-30 PM450-32 PM450-34 PM450-36	Live	Neutral	Ground	+V01	+V01	Signal (-V01)	Ground	+S(V01)	-S(V01)	PFD	Inhibit	Inhibit -ve	-S(V02)	-S(V02)	0V (Fan)	Fan

PM450 Series

450-480 WATTS SINGLE & MULTIPLE OUTPUT AC/DC MEDICAL

		P5			
MODEL/PIN		1	2	3	4
PM450-20	PM450-21				
PM450-22	PM450-23	+V2	-V2	N.C.	N.C.
PM450-24					
PM450-30	PM450-31				
PM450-32	PM450-33	+V2	-V2	+V3	-V3
PM450-34	PM450-35				
PM450-36	PM450-37				

Technical Illustration

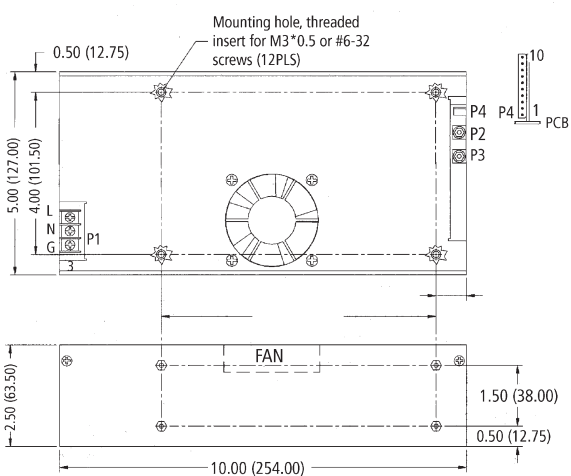

SINGLE

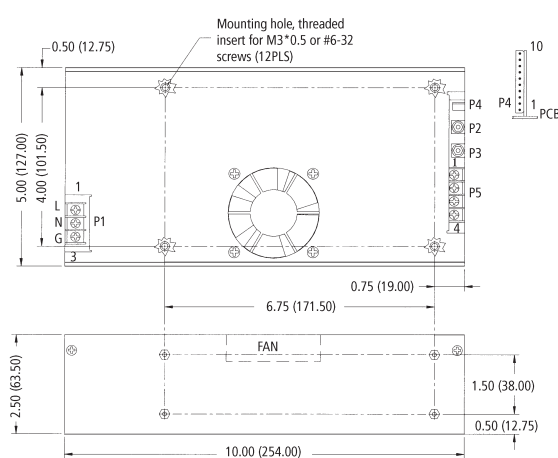

MULTIPLE